

NOTE: ALL DIMENSIONS ARE IN INCHES.
 MATERIALS OF CONSTRUCTION:
 BASE ELBOW: CAST DUCTILE IRON
 LIFT-OUT FLANGE: CAST DUCTILE IRON
 W/BRONZE SEALING RING
 LOWER GUIDE BRACKET: BRONZE
 ALL FASTENERS ARE 304 SERIES SST
 USEABLE GUIDE RAIL SIZES: 2"
 SPHERICAL SOLIDS SIZE: 6" Diameter.
 MAXIMUM WEIGHT ALLOWANCE: 2000lbs.

BERS-0600HEX

PAGE
1

MOUNTING DIMENSIONS

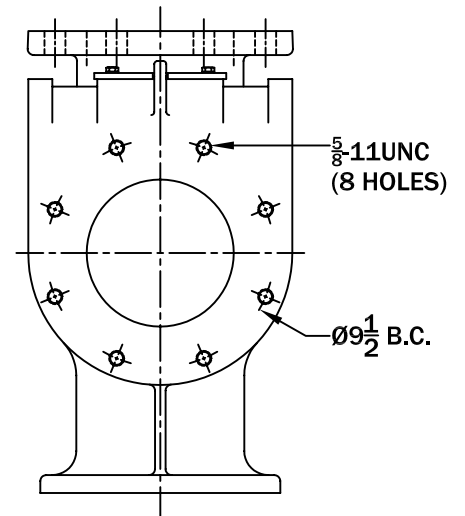
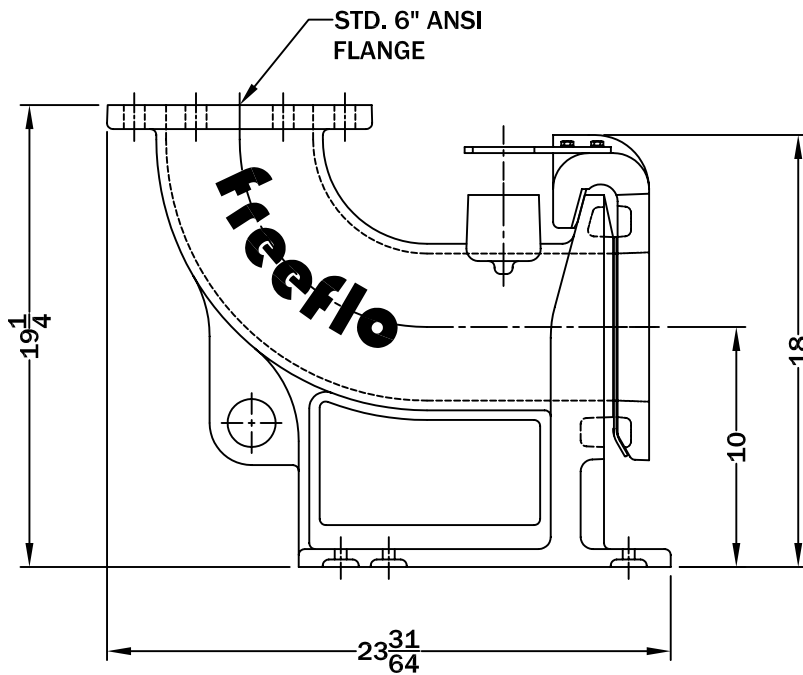
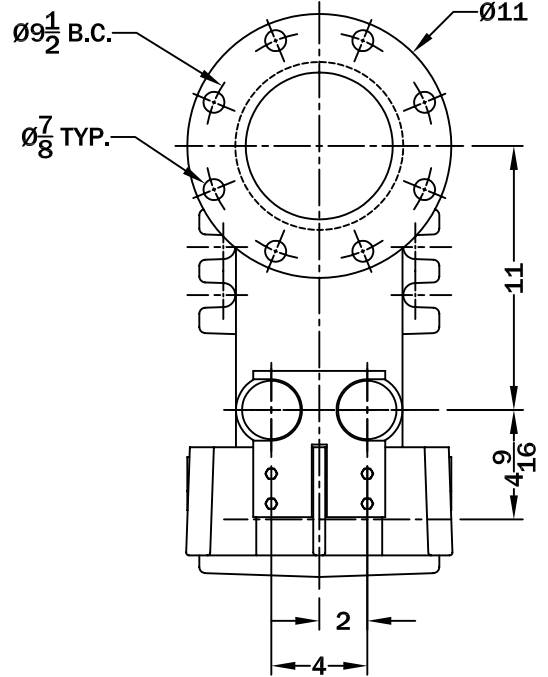
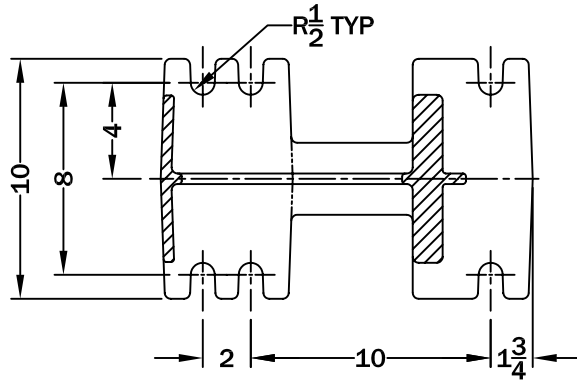

ALL INFORMATION CONTAINED IN THIS DRAWING IS
 CONFIDENTIAL AND PROPRIETARY TO CONERY MFG, INC.



CHANGES	TOLERANCES	DRAWN BY	DATE
F	DECIMALS	D. MIDDLETON	03/17/07
E	.xxx = ±.005	MATERIAL SPECIFICATION: AS NOTED	
D	.xx = ±.010		
C	FRACTIONAL		
B	x/x = ±.1/64		
A	ANGLES		
	x' = ±1/2'		

SPECIFICATION SHEET
 DIMENSIONAL DATA

SCALE: PART NO.
 1/8 6" LIFT-OUT DIM.