

NOTE: ALL DIMENSIONS ARE IN INCHES.

MATERIALS OF CONSTRUCTION:

BASE ELBOW: CAST DUCTILE IRON

LIFT-OUT FLANGE: CAST DUCTILE IRON

W/SST SEALING RING

LOWER GUIDE BRACKET: CAST DUCTILE IRON

ALL FASTENERS ARE 304 SERIES SST

USEABLE GUIDE RAIL SIZES: 1½" & 2"

SPHERICAL SOLIDS SIZE: 4" Diameter.

MAXIMUM WEIGHT ALLOWANCE: 2000lbs.

BERS-0400

PAGE
1

MOUNTING DIMENSIONS

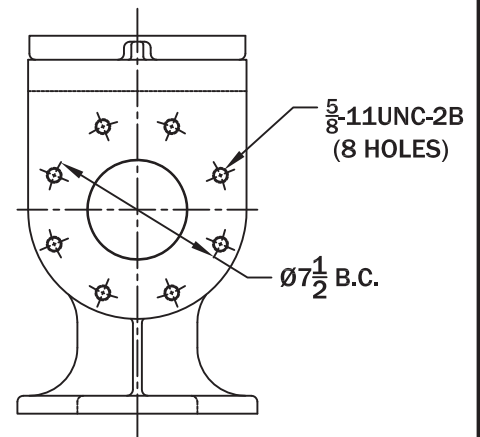
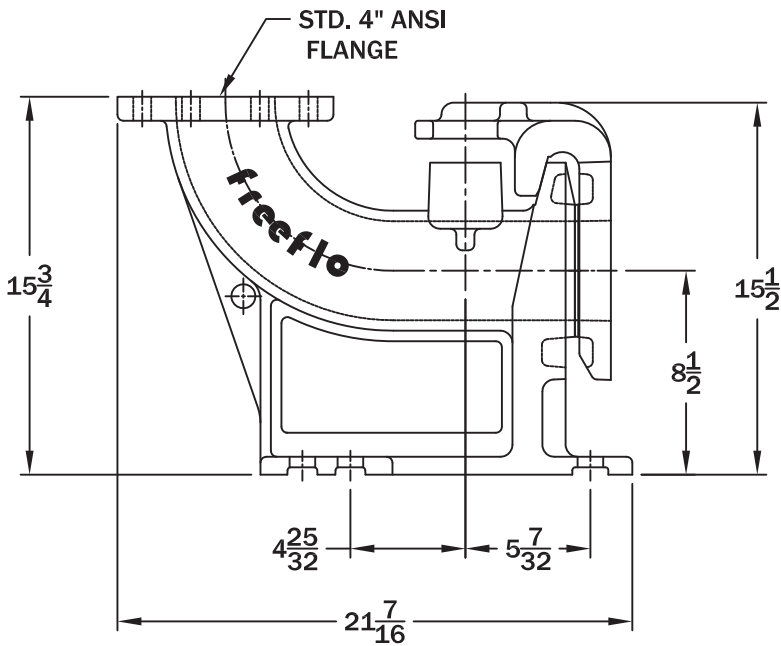
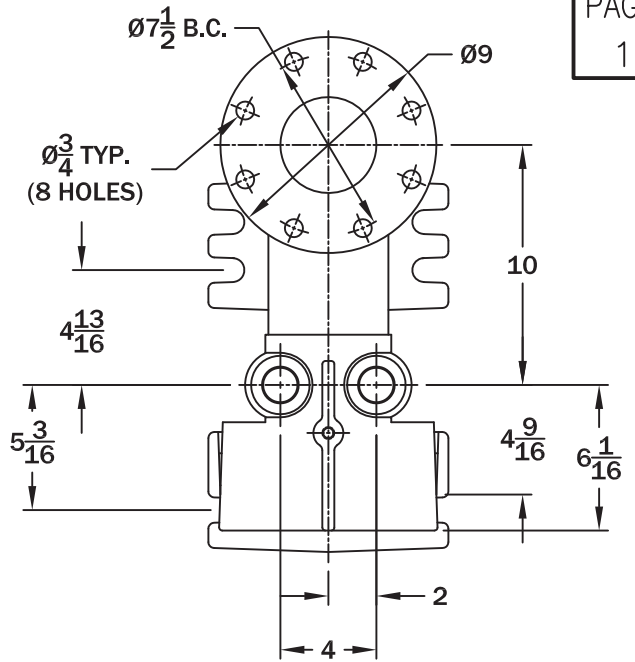
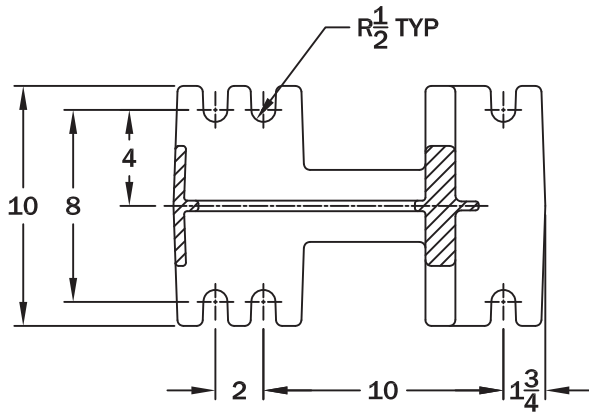

ALL INFORMATION CONTAINED IN THIS DRAWING IS CONFIDENTIAL AND PROPRIETARY TO CONERY MFG, INC.



CHANGES	TOLERANCES	DRAWN BY	DATE
F	DECIMALS	D. MIDDLETON	07/15/04
E	.XXX = ±.005	MATERIAL SPECIFICATION: AS NOTED	
D	.XX = ±.010		
C	FRACTIONAL		
B	X/X = ±.1/64		
A	ANGLES		
	X° = ±1/2°		

SPECIFICATION SHEET
DIMENSIONAL DATA

SCALE: PART NO.
1/8 4" LIFT OUT DIM