

Pull Out Flange Assembly Instructions: Figure 1 shows all of the parts included with the pull-out flange assembly. This is the removable portion of the Freeflo™ base elbow rail system assembly, and it is this assembly that will attach to the discharge of the pump (see figure 2). The threaded pump adapter flange will thread into the pump discharge as shown. The pump adapter flange is secured by tightening the two (2) long cap screws provided. This allows the pump to be oriented as necessary before lowering into the basin or collection tank. After attaching the pull out flange assembly to the pump, the lifting chain or cable assembly should be attached (see figure 3). This should be adequately sized to handle the weight of the pump and the pull out flange assembly as well as be long enough to allow for easy access for pulling the pump (continued on reverse side of this page).

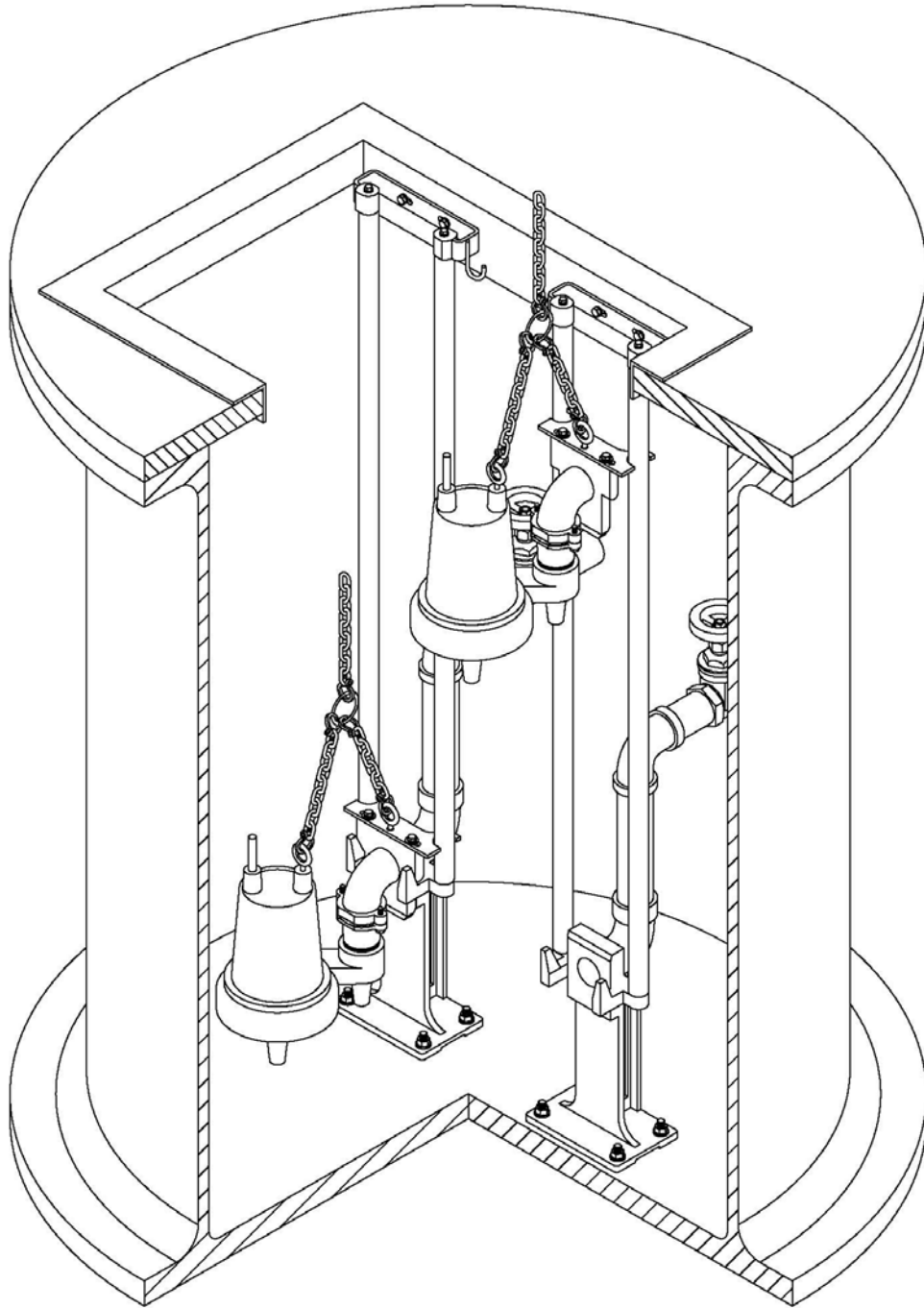

Base Elbow Installation Instruction: There are two main components to the Freeflo™ base elbow rail system, the stationary base and the pull out flange assembly. The stationary base will be secured to the bottom of the basin or collection tank. The base elbow should be positioned per the job specifications and the pump manufacturer's recommendations to allow for proper alignment with the access hatch for removal and installation of the pump or pumps. The base elbow is designed to be secured with four (4) studs, lock-washers, and nuts. It is important to make sure the elbow is secured to the basin or collection tank bottom to prevent it from moving or vibrating. After the elbow is installed the remaining items can be installed (i.e. piping, valve, guide rails, rail supports, etc.) into the tank. After this is done simply attach the pull out flange assembly to the pump, and lower the pump into the tank as shown above.